

ennin
VIBRATORY EQUIPMENT

tubular tray options

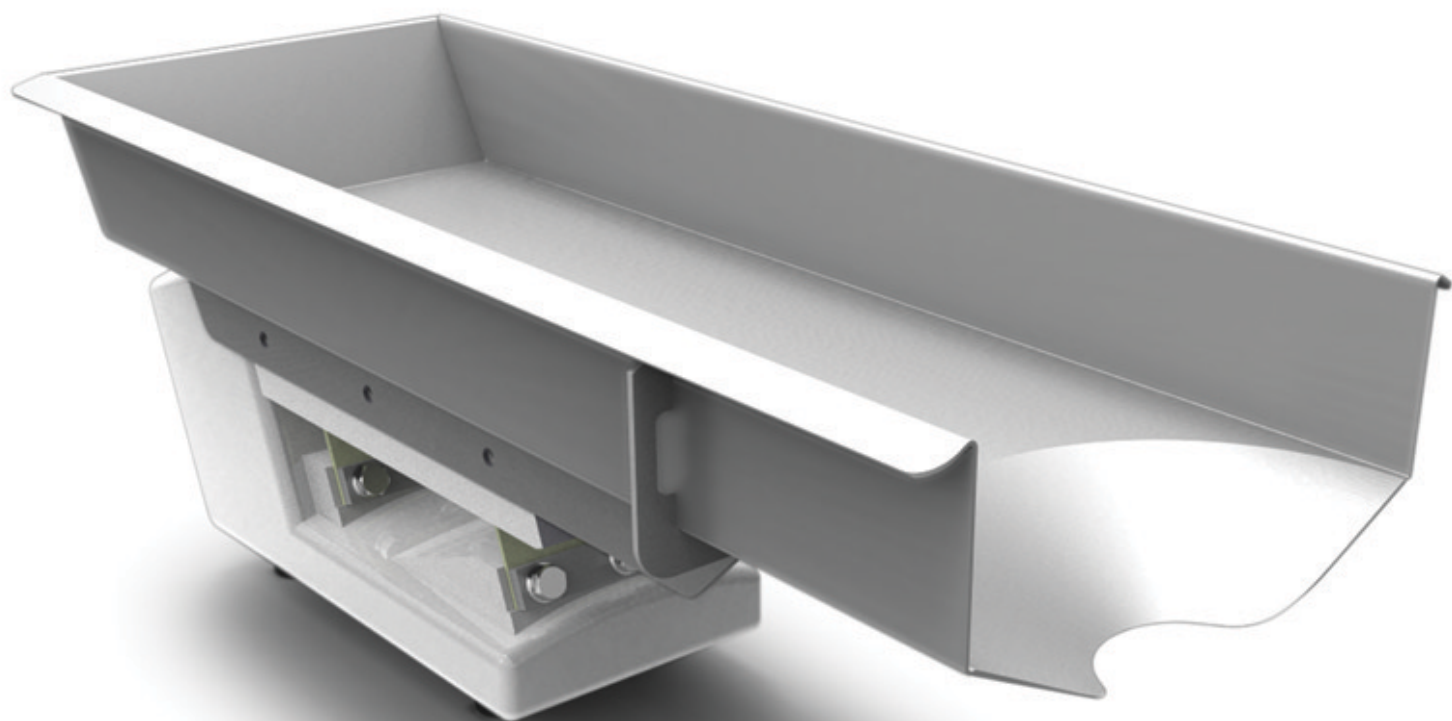

TUBULAR

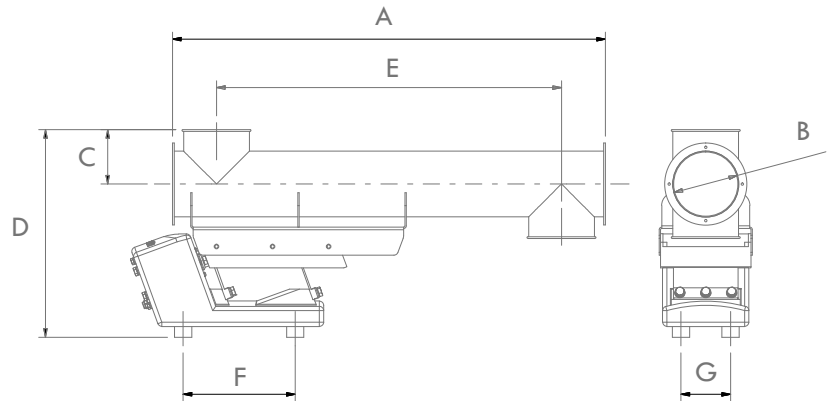
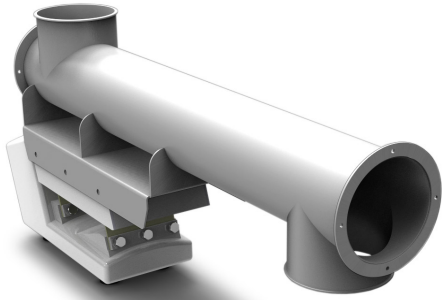

LD1

	A	B	C	D	E	F	G
STANDARD	450	76	76	283	350	180	40
WIDE	400	89	89	296	300	180	40
LONG	500	63.5	63.5	270	400	180	40
MEDIUM	450	76	76	283	350	180	40

APPLICATIONS

The tubular tray option is normally utilised when enclosure of fine, dusty product is required or contamination is of concern.

LD2

	A	B	C	D	E	F	G
STANDARD	650	102	102	370	450	180	60
WIDE	600	127	127	395	400	180	60
LONG	700	89	89	357	500	180	60
MEDIUM	650	102	102	370	450	180	60

These tubes are often fitted with quick release ports at both inlet and outlet to allow ease of inspection and maintenance.

LD3

	A	B	C	D	E	F	G
STANDARD	800	127	127	410	600	215	90
WIDE	700	152	152	435	500	215	90
LONG	900	102	102	385	700	215	90
MEDIUM	800	127	127	410	600	215	90

If necessary, dust extraction ports can be incorporated.

LD4

	A	B	C	D	E	F	G
STANDARD	1100	152	152	482	800	260	115
WIDE	1000	203	203	533	700	260	115
LONG	1200	127	127	457	900	260	115
MEDIUM	1100	152	152	482	800	260	115

Note: Information presented may be updated without notification. Please consult Enmin if exact dimensions are required