

**enmm**  
V I B R A T O R Y   E Q U I P M E N T

# standard tray options

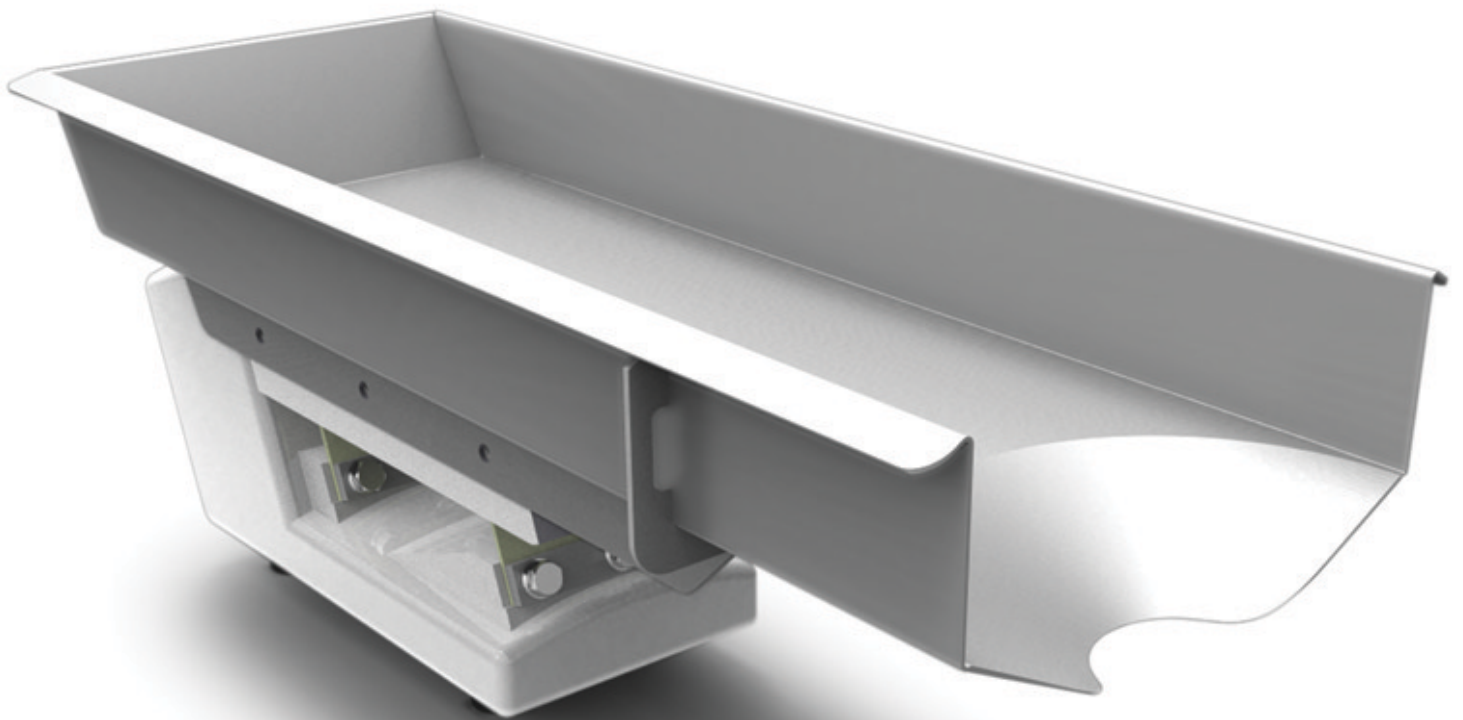

# RECTANGULAR

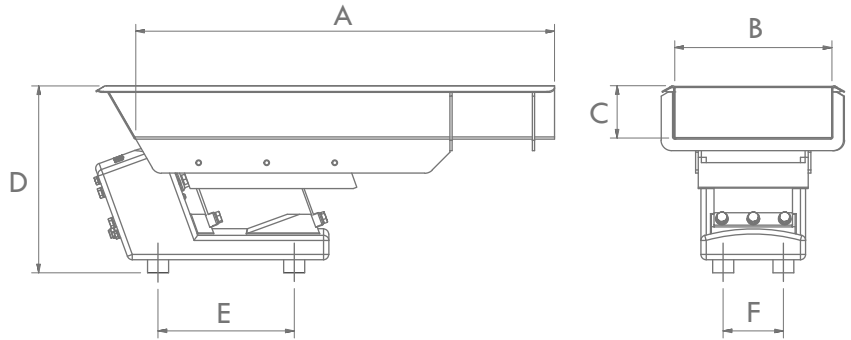

## LD1

	A	B	C	D	E	F
STANDARD	400	150	50	182	180	40
WIDE	250	250	50	182	180	40
LONG	500	100	50	182	180	40
MEDIUM	400	100	50	182	180	40

## LD2

	A	B	C	D	E	F
STANDARD	500	200	75	245	60	180
WIDE	400	300	75	245	60	180
LONG	700	175	75	245	60	180
MEDIUM	550	200	75	245	60	180

## LD3

	A	B	C	D	E	F
STANDARD	650	275	100	300	215	90
WIDE	500	350	100	300	215	90
LONG	1000	200	100	300	215	90
MEDIUM	850	250	100	300	215	90

## LD4

	A	B	C	D	E	F
STANDARD	850	350	100	350	260	115
WIDE	600	400	100	350	260	115
LONG	1500	300	100	350	260	115
MEDIUM	1000	350	100	350	260	115

## APPLICATIONS

The rectangular tray is the most commonly used tray and allows a reasonable volume of product to be accumulated and fed at constant rates to subsequent processing equipment.

A variety of tray widths, lengths and depths are offered depending on the size of the selected drive.

These trays can be up to 3000mm long and as wide as 1200 mm for spreading applications.

Note: Information presented may be updated without notification. Please consult Enmin if exact dimensions are required